

Installation and operation manual

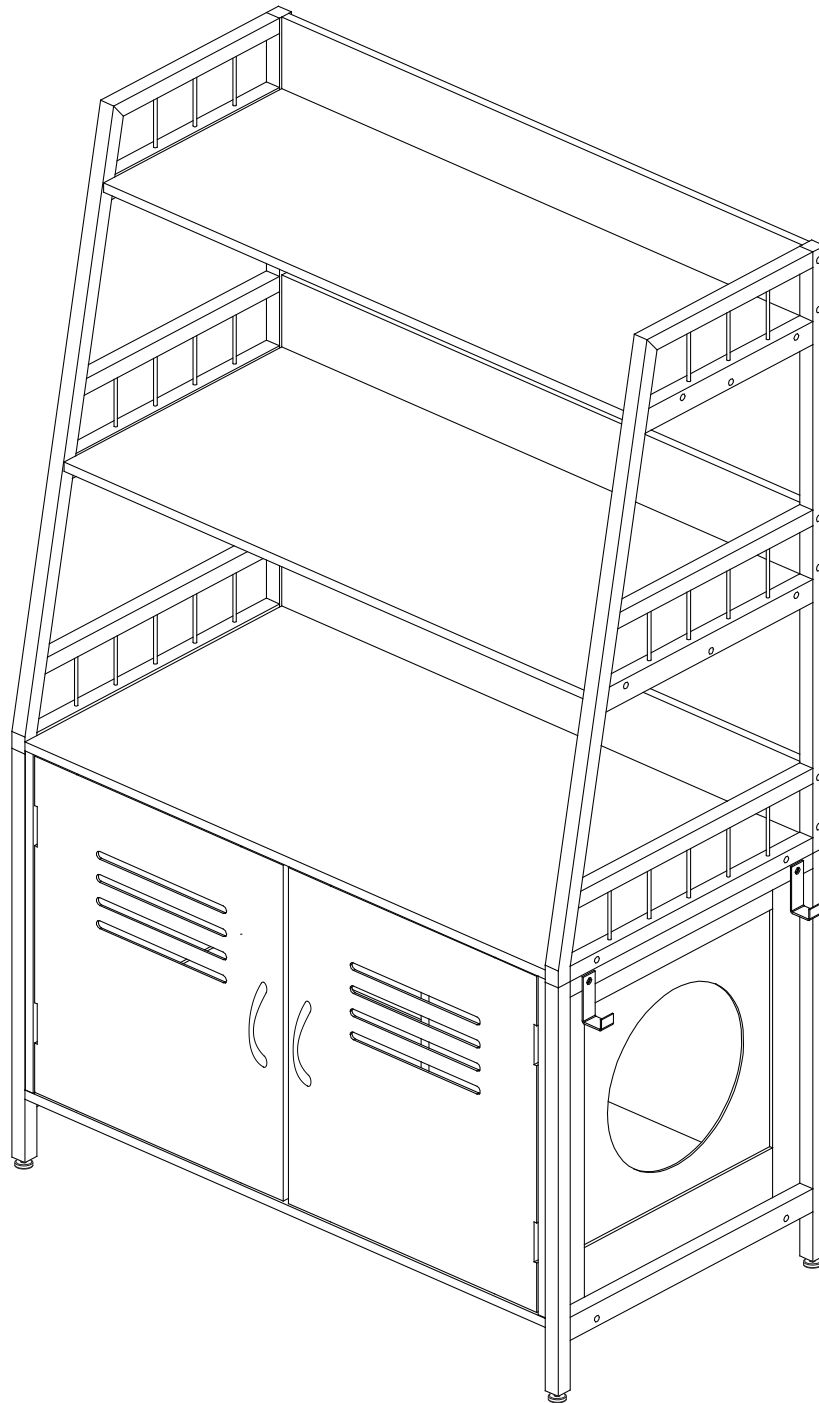

BOARD IDENTIFICATION

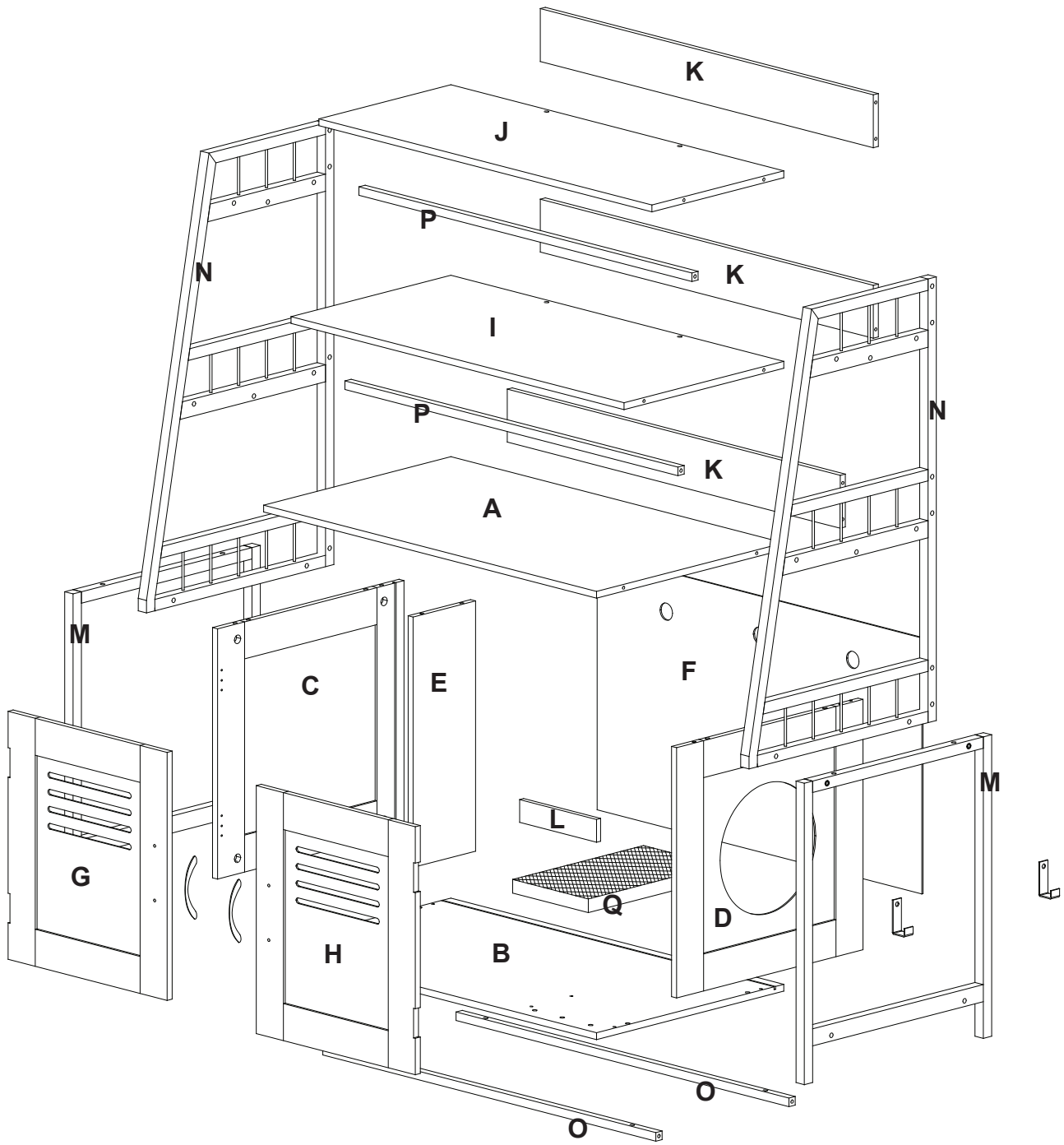

BOARDIDENTIFICATION

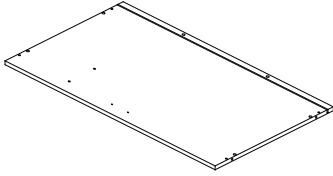
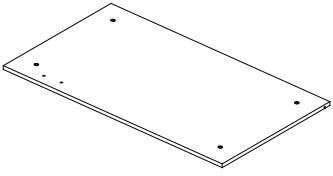
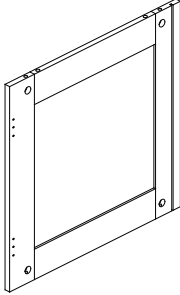
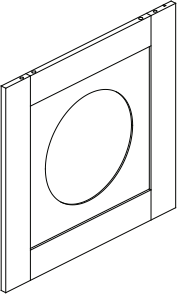
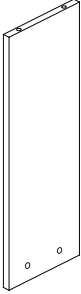
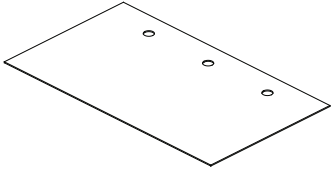
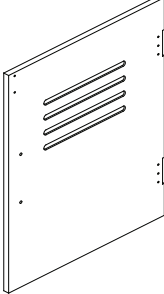
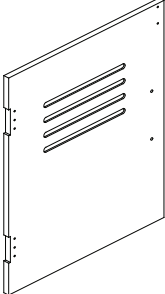
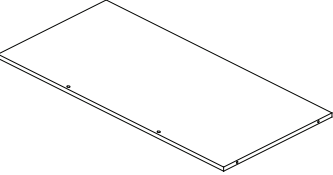
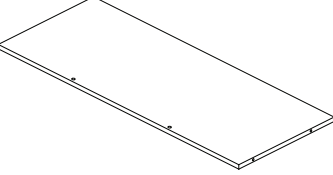
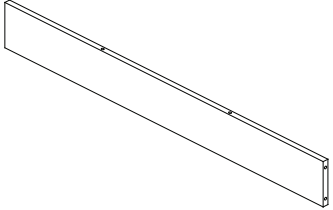
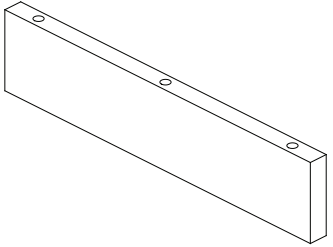
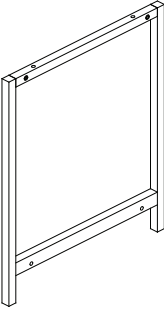
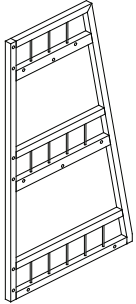
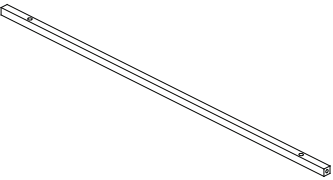
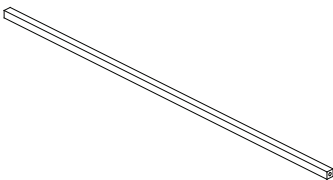
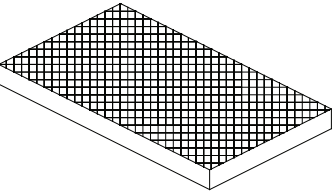
			
Ax1	Bx1	Cx1	Dx1
			
Ex1	Fx1	Gx1	Hx1
			
Ix1	Jx1	Kx3	Lx1
			
Mx2	Nx2	Ox2	Px2
			
Qx1			

BOARD IDENTIFICATION

Installation principle of eccentric parts

1

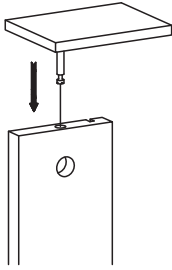

Screw the eccentric screw onto the plate to find the corresponding plate to insert

2

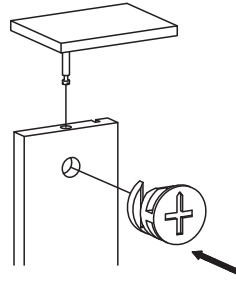

Insert the eccentric screw into the round hole with the arrow pointing to the screw

3

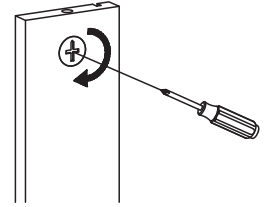

Turn clockwise 180° to lock the board

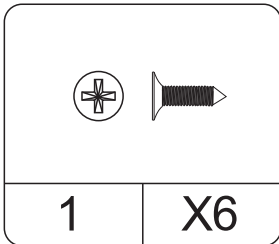

1 X6

Screws M3X10

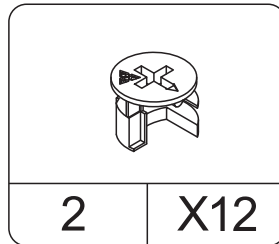

2 X12

Cam lock \varnothing 15X10

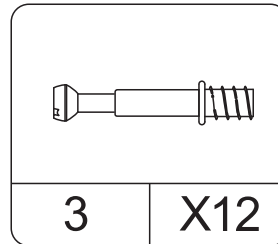

3 X12

Cam bolt \square 6.5X27

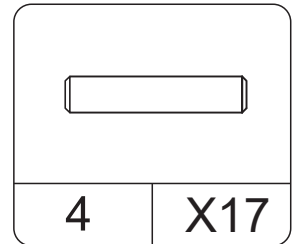

4 X17

Wood dowel \square 6X30

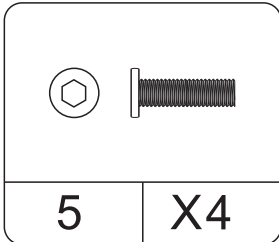

5 X4

Screws M6X23

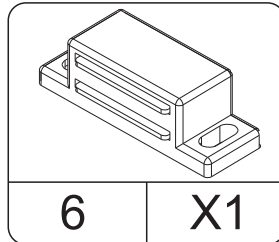

6 X1

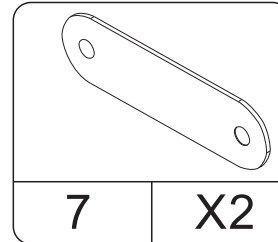

7 X2

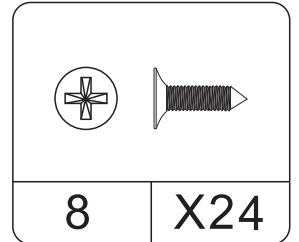

8 X24

Screws M4X10

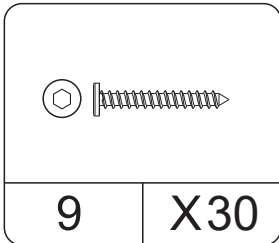

9 X30

Screws M6.3X50

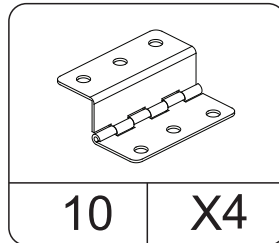

10 X4

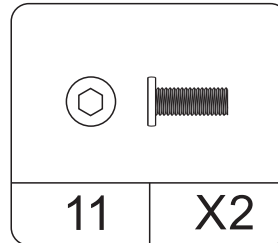

11 X2

Screws M6X12

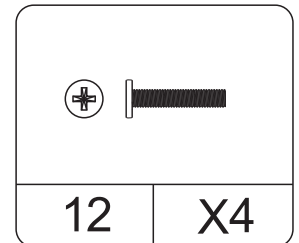

12 X4

Screws M4X18

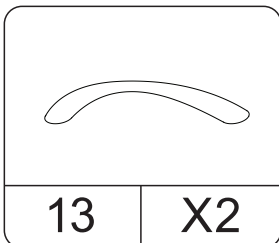

13 X2

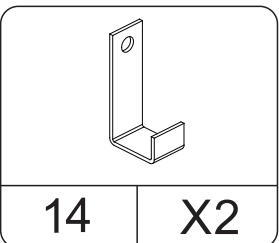

14 X2

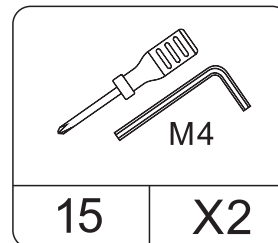

15 X2

M4

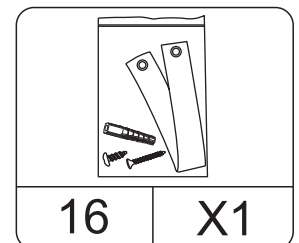

16 X1

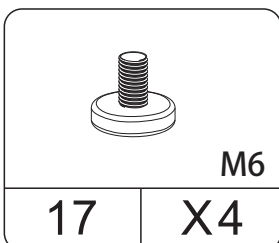

M6

17 X4

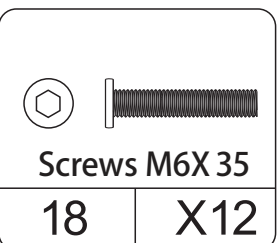

Screws M6X35

18 X12

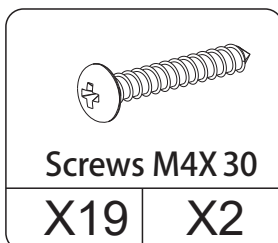

Screws M4X30

X19 X2

INSTALLATION STEPS

STEP1:

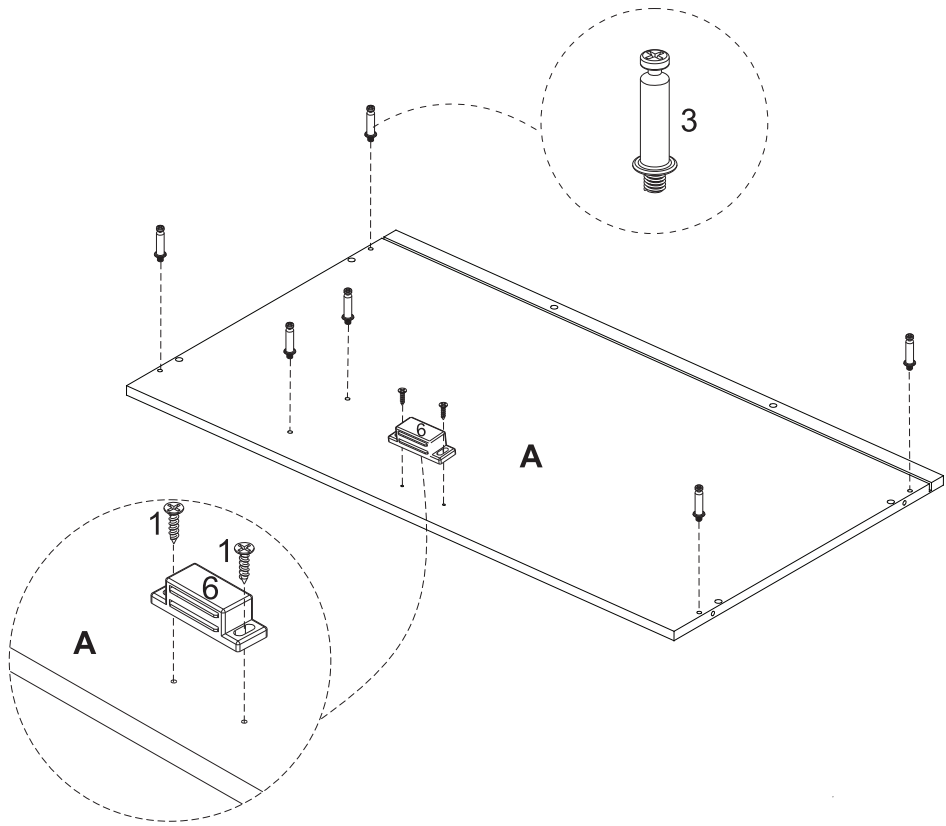
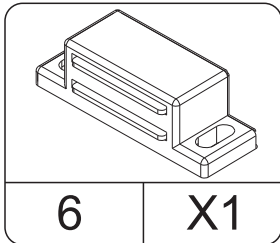
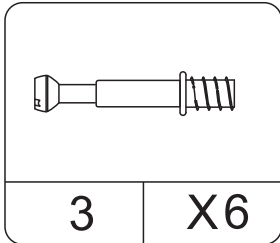
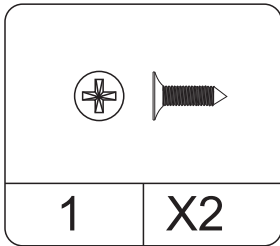

STEP2:

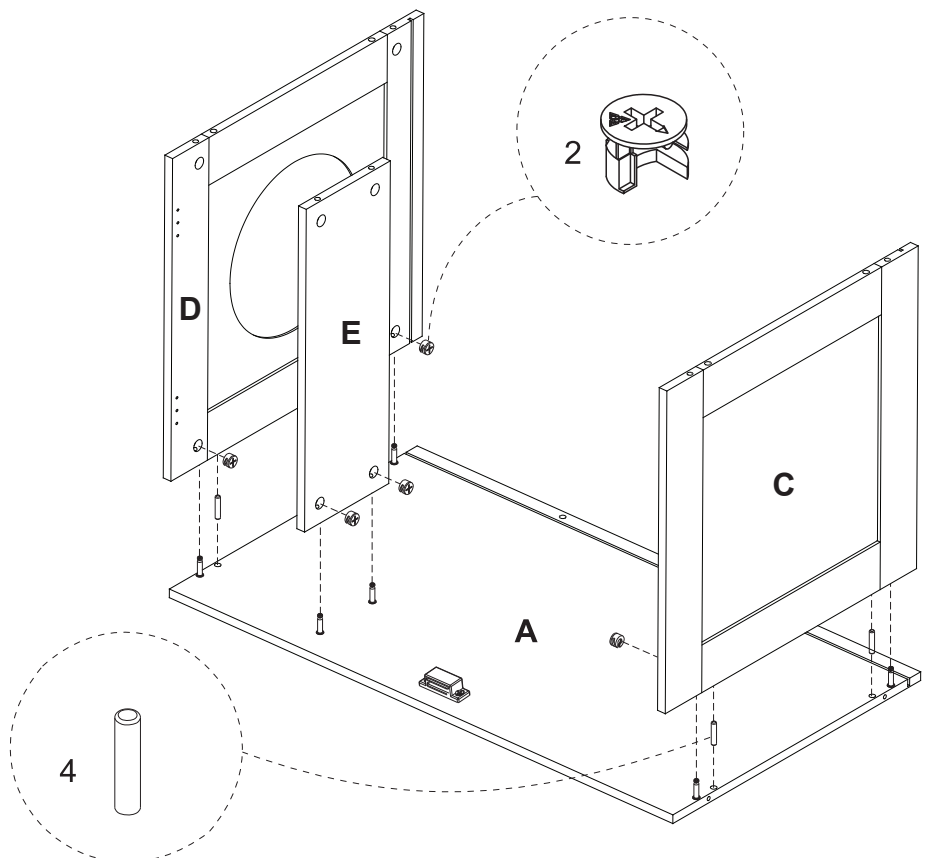
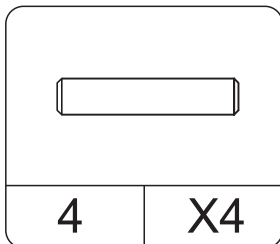
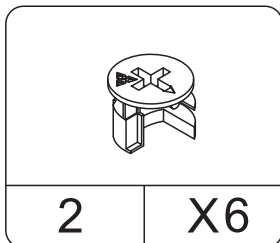

INSTALLATION STEPS

STEP3:

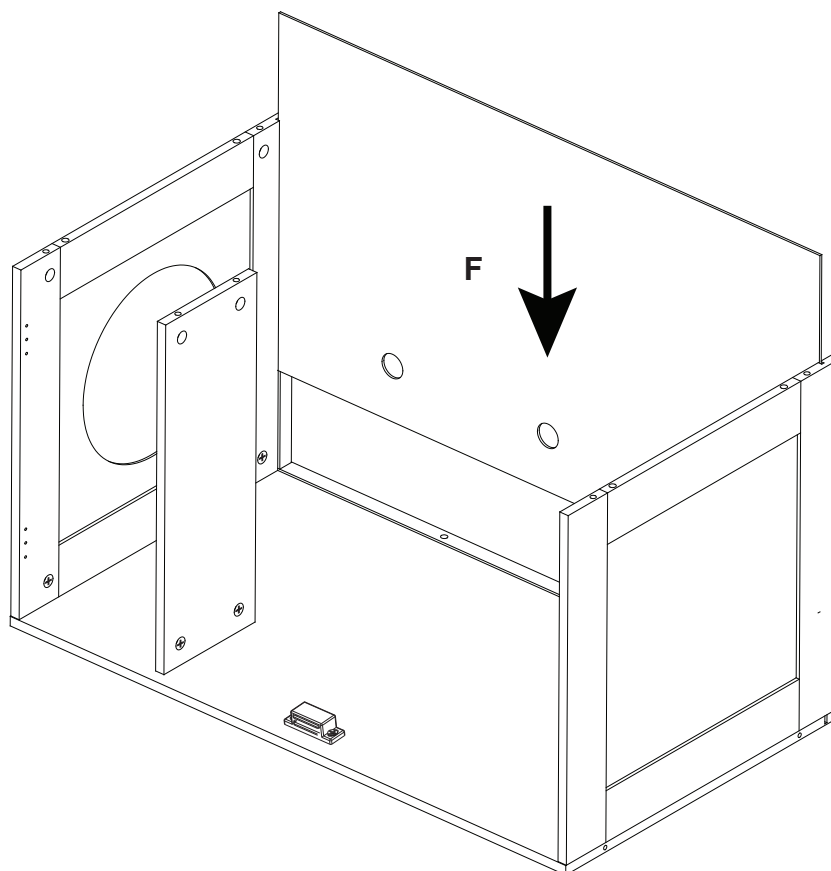

STEP4:

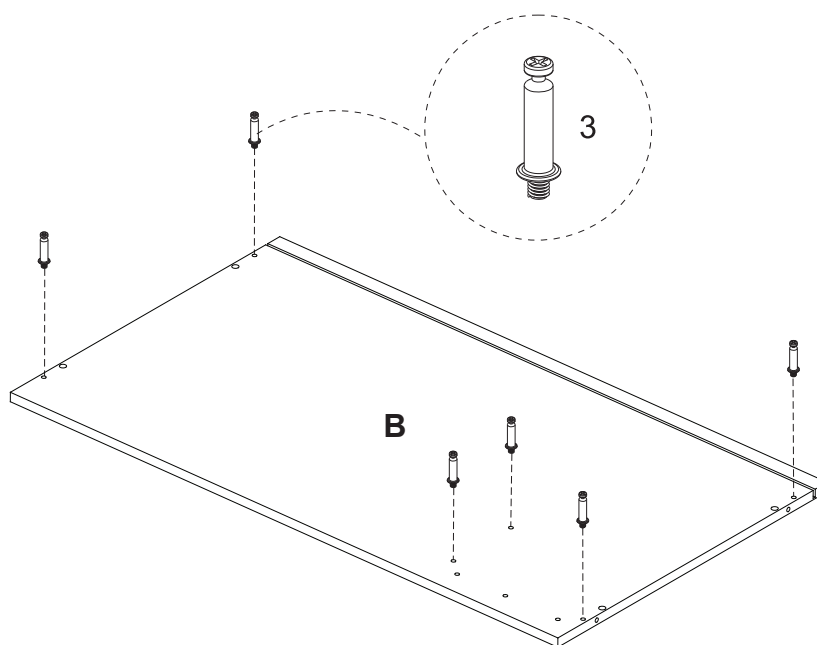
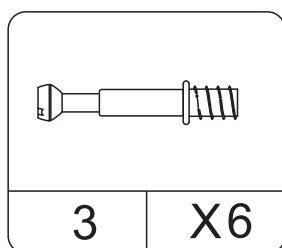

INSTALLATION STEPS

STEP5:

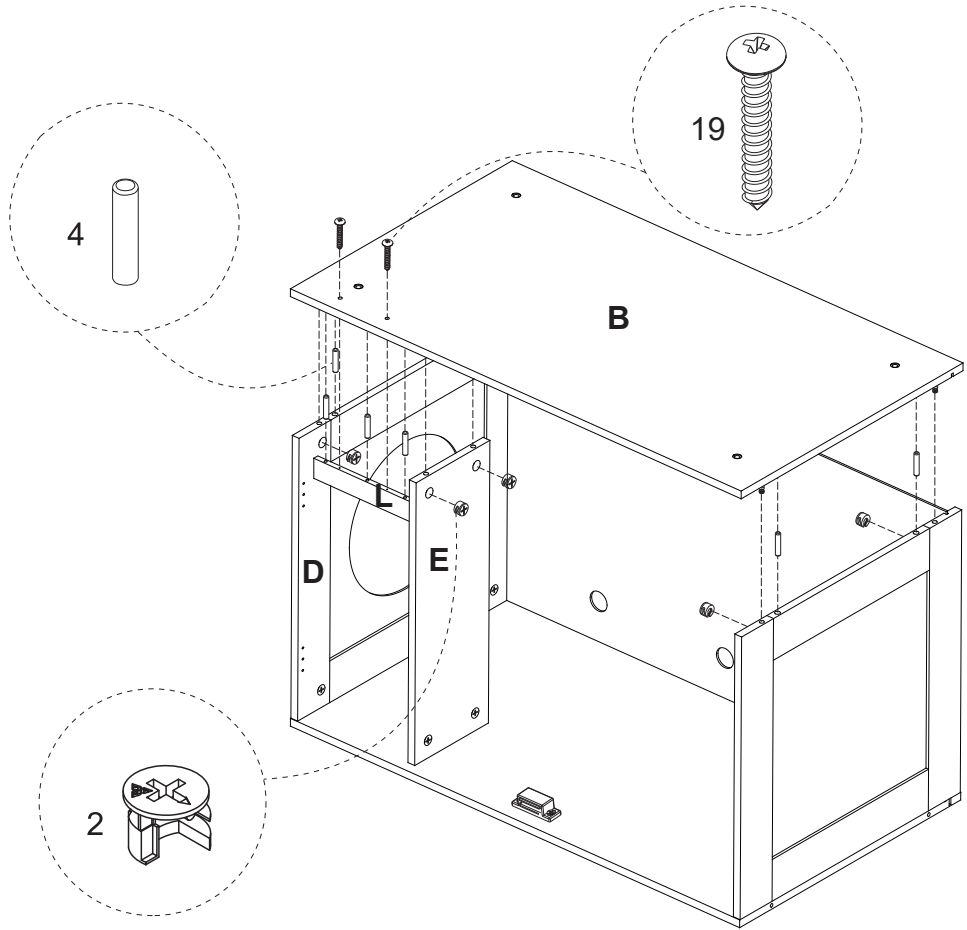
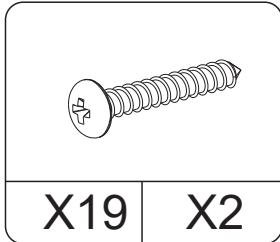
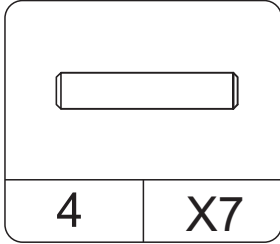
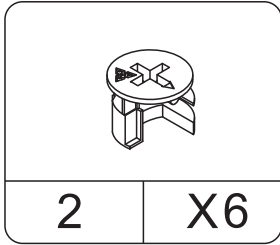

STEP6:

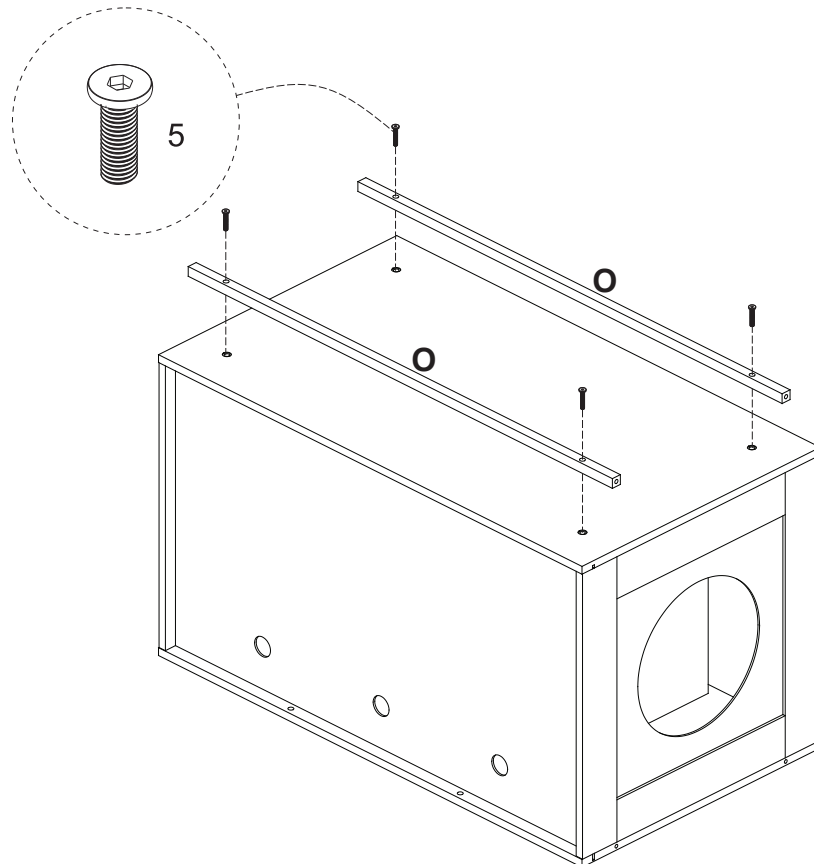
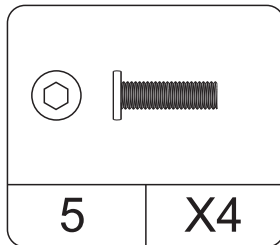

INSTALLATION STEPS

STEP7:

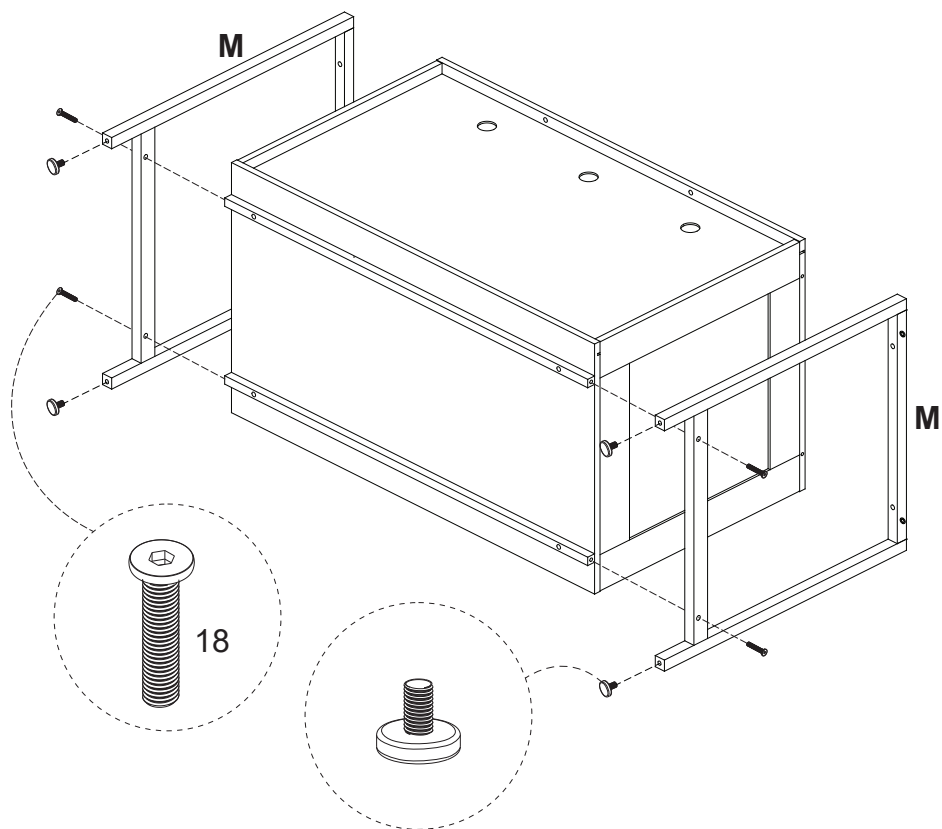
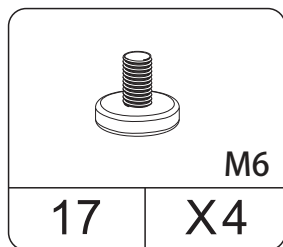
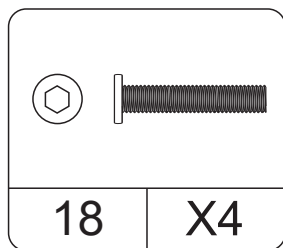

STEP8:

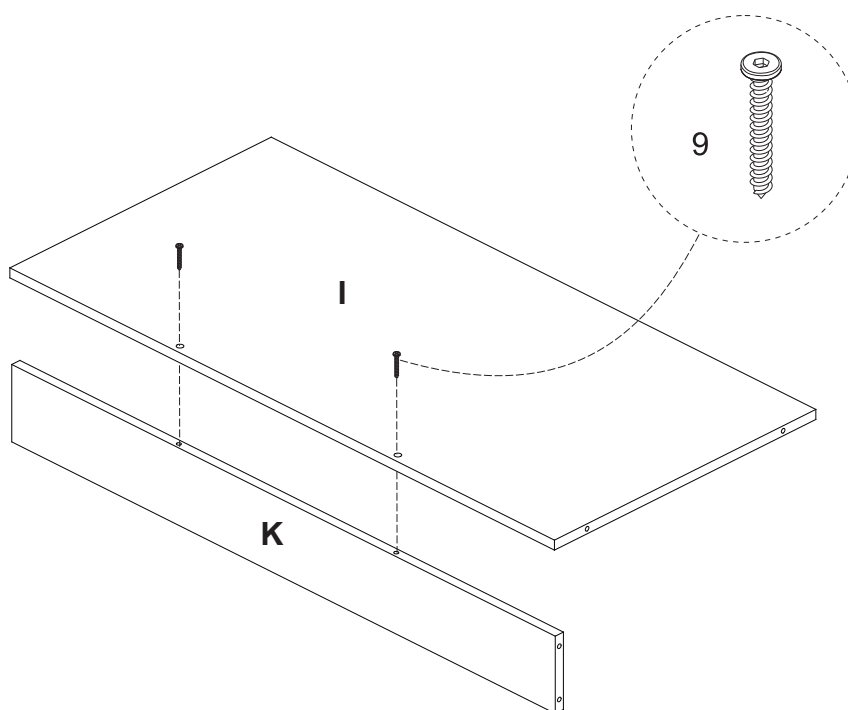
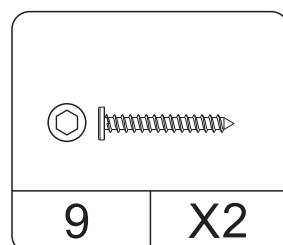

INSTALLATION STEPS

STEP9:

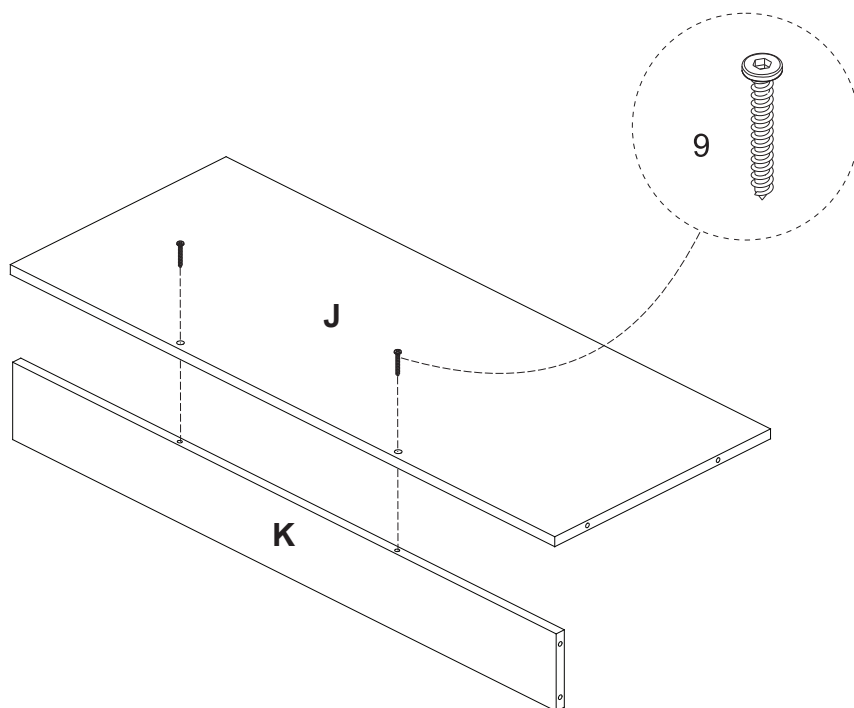
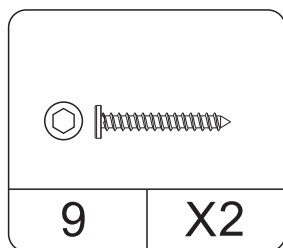

STEP10:

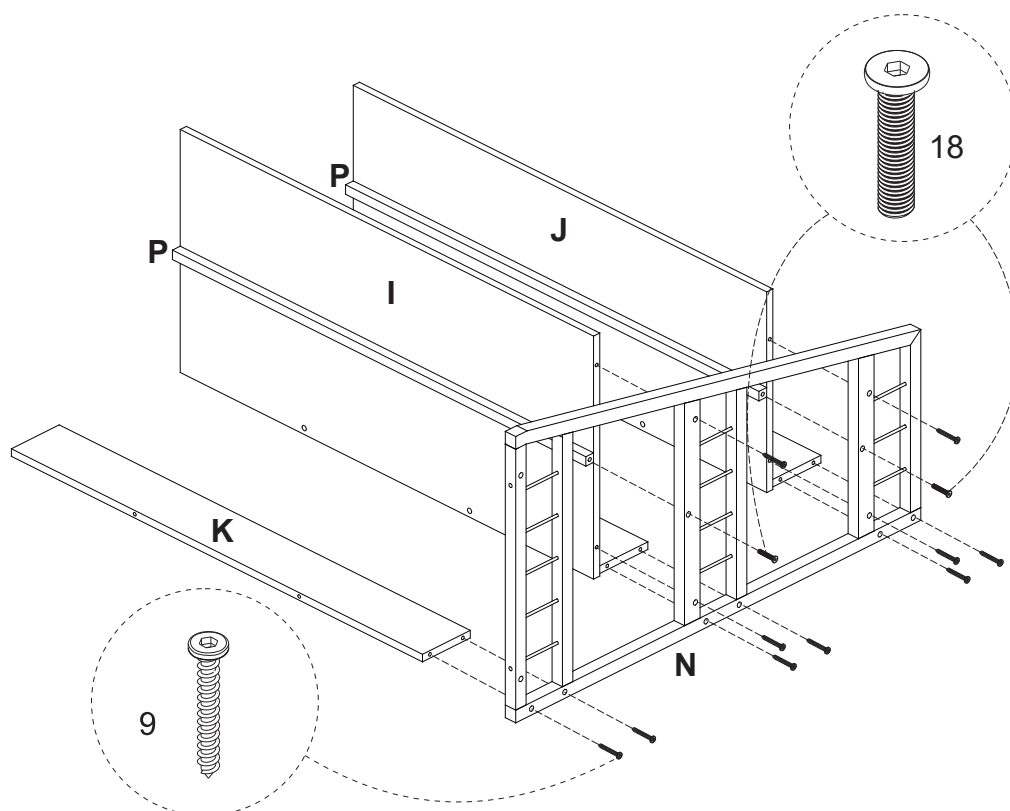
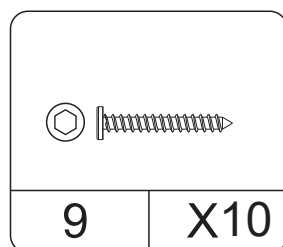
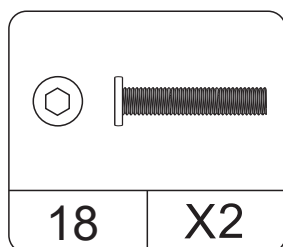

INSTALLATION STEPS

STEP11:

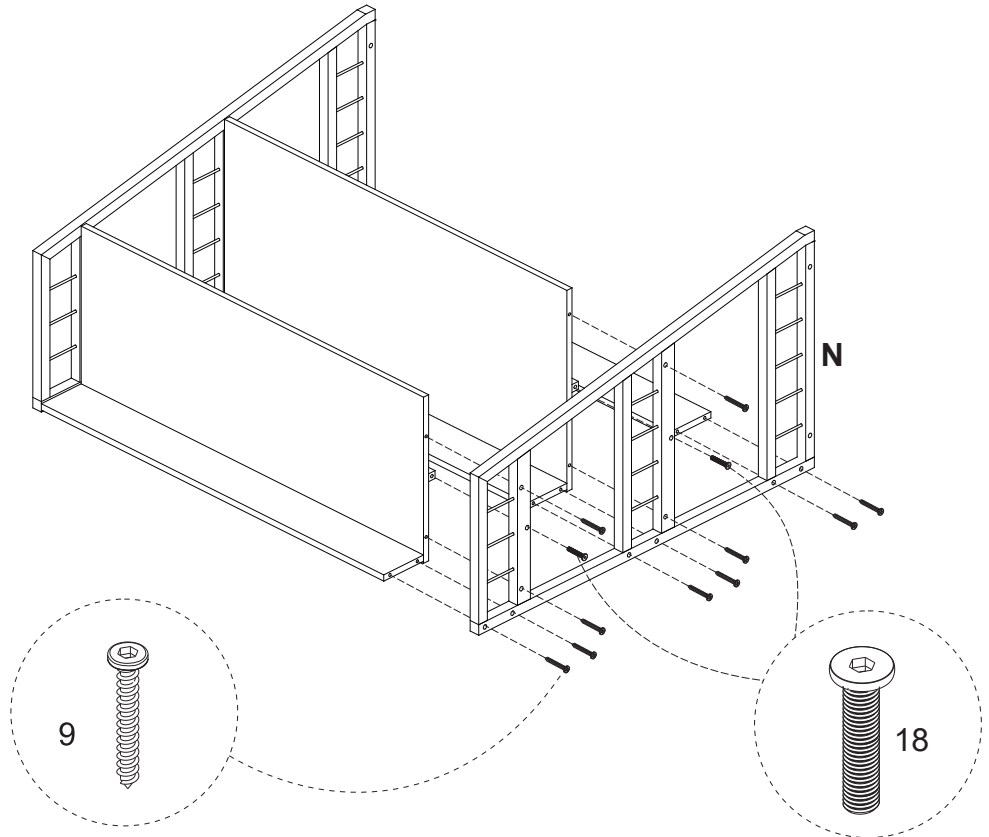
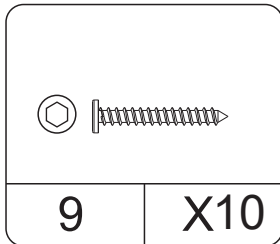
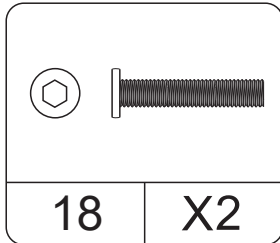

STEP12:

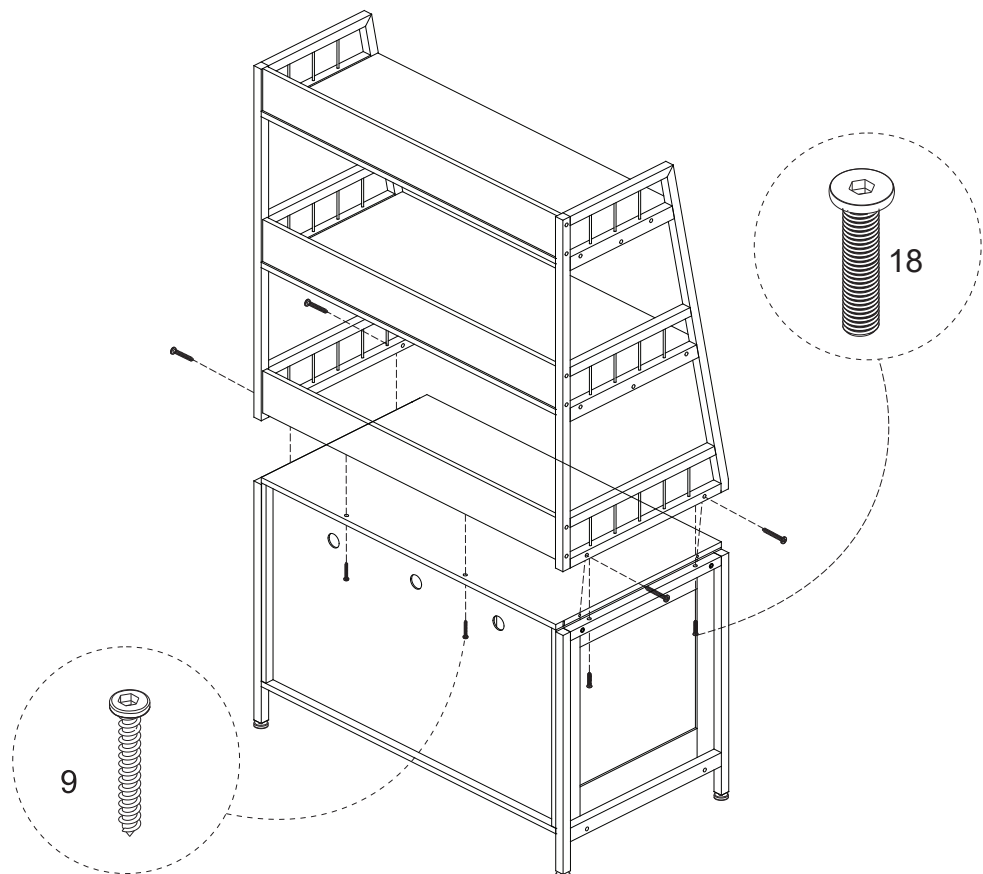
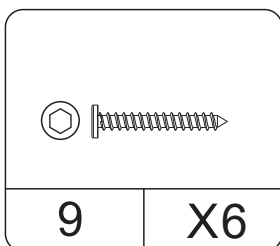
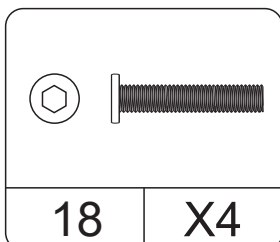

INSTALLATION STEPS

STEP13:

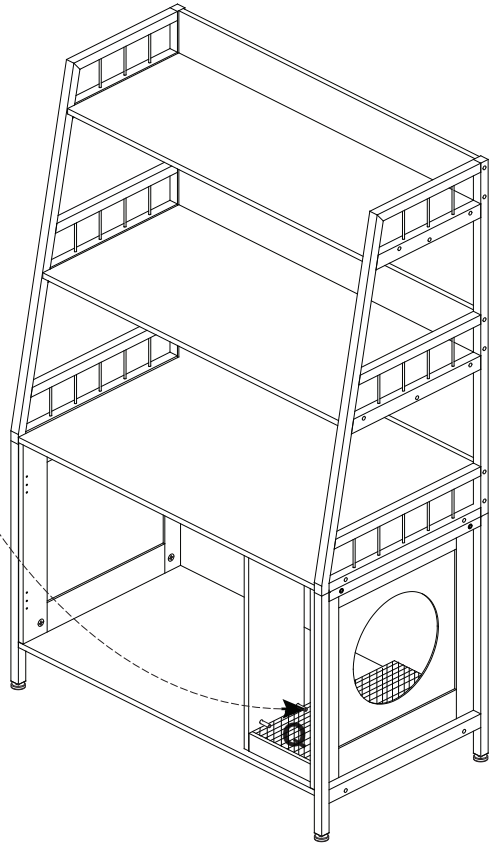
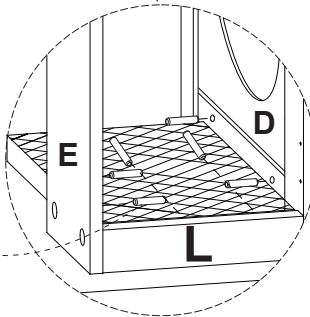
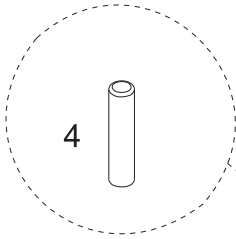
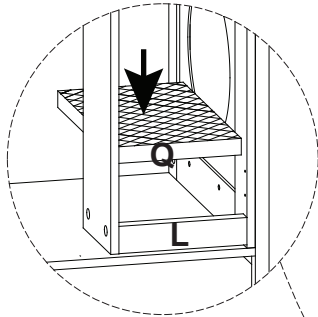
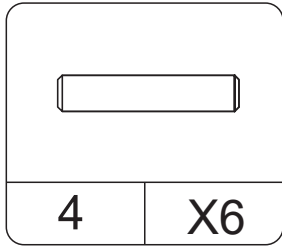

STEP14:

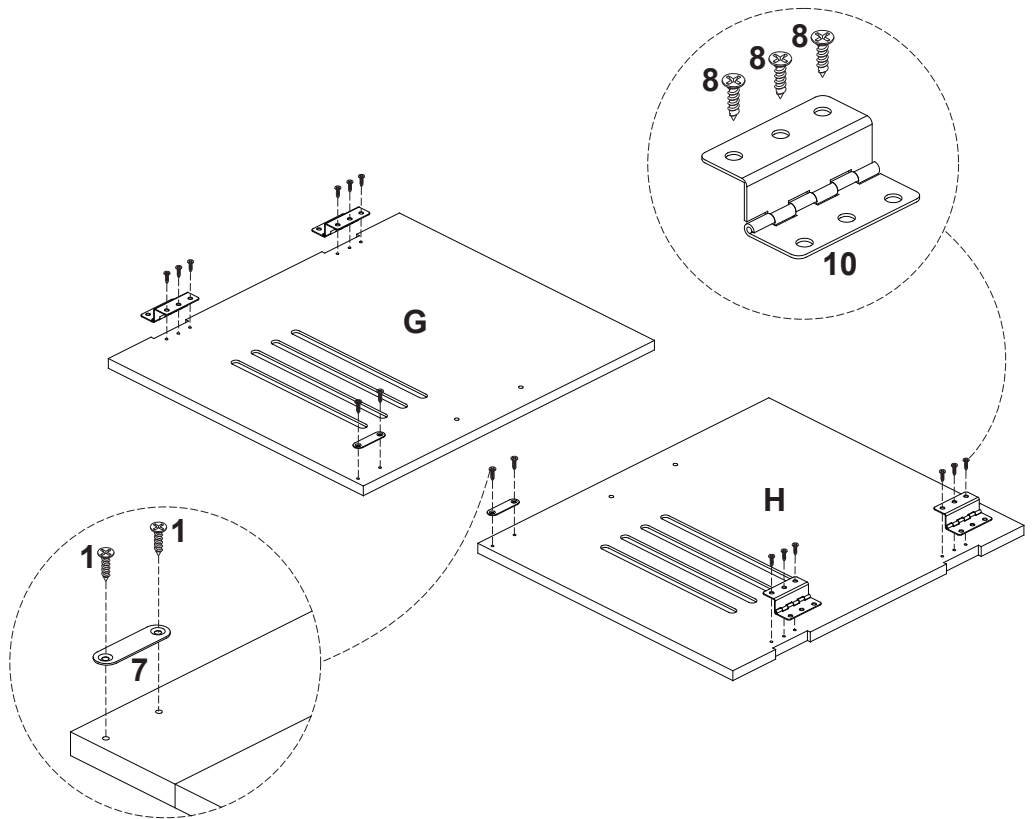
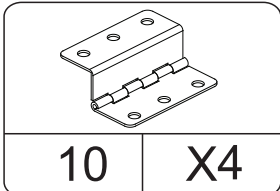
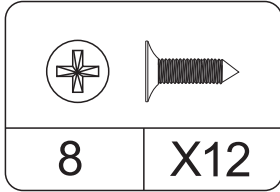
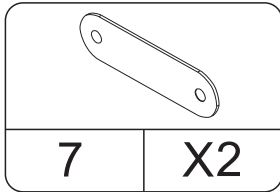
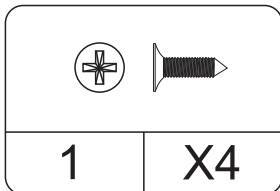

INSTALLATION STEPS

STEP15:

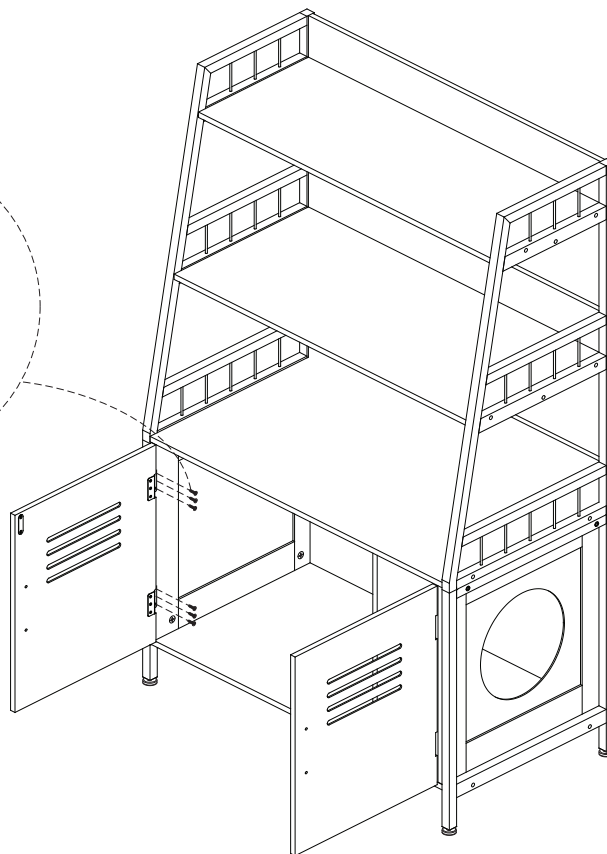
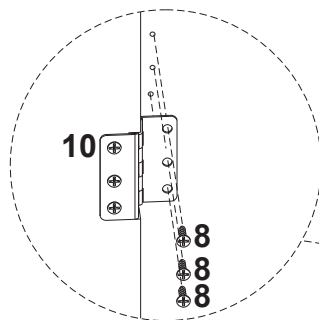
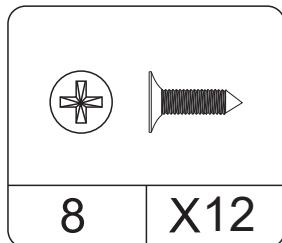

STEP16:

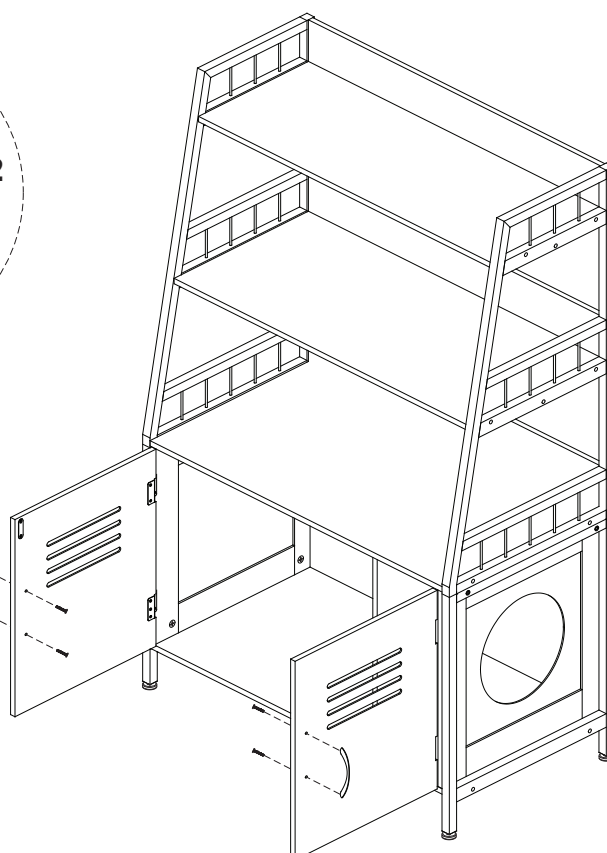
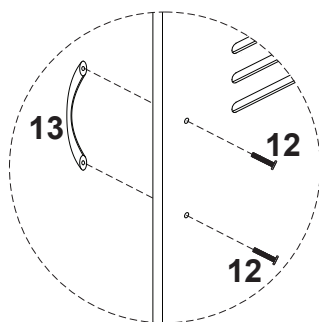
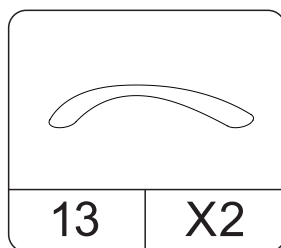
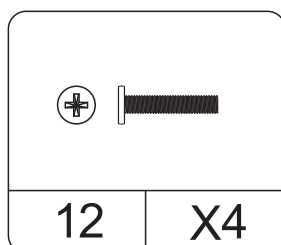

INSTALLATION STEPS

STEP17:

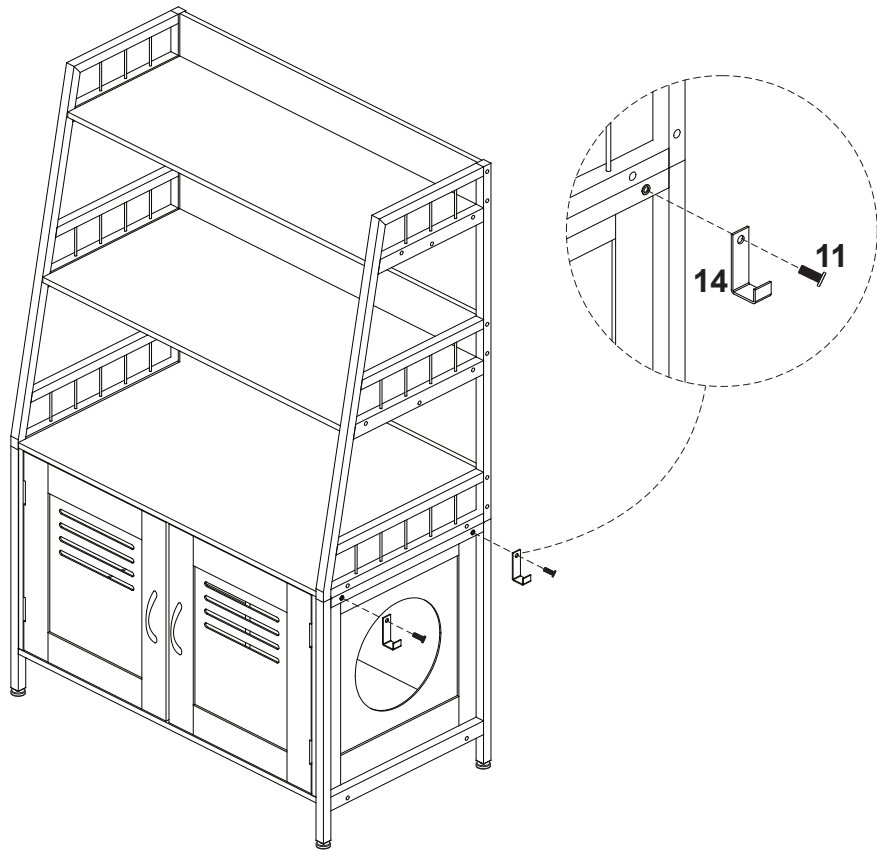
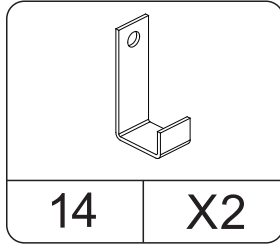
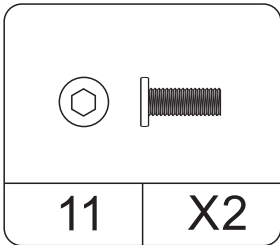

STEP18:

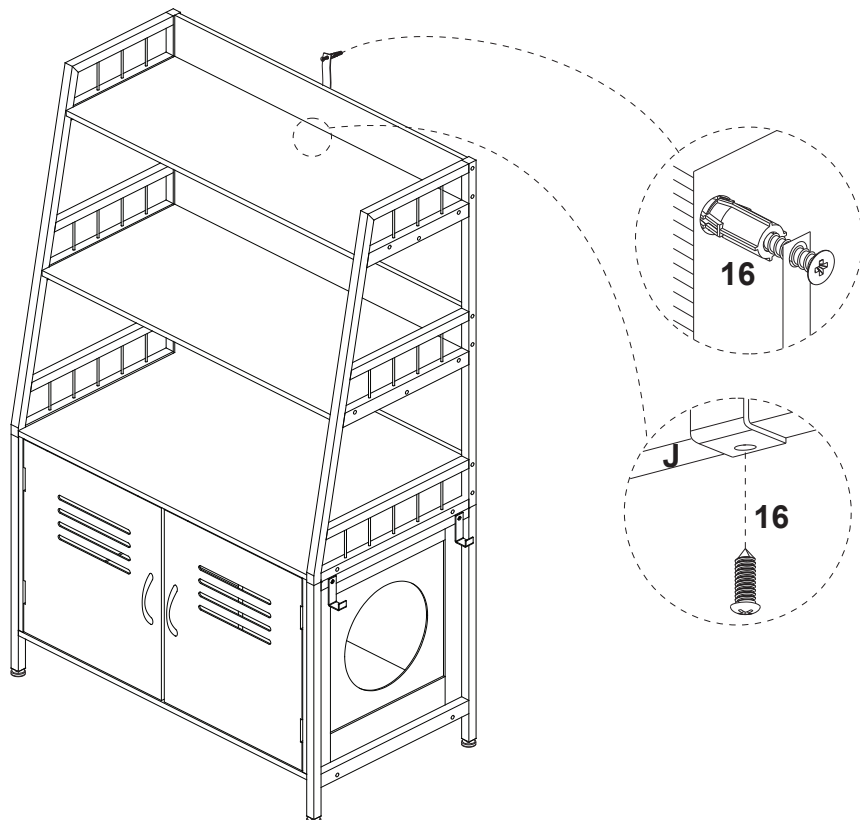
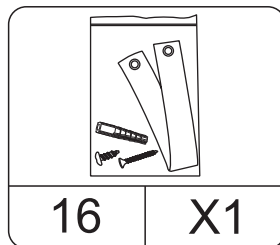

INSTALLATION STEPS

STEP 19:

